

# Programm 063 - Maßskizzen

WTA 0805 + SET 387S

WTA 0805 + SET 381S

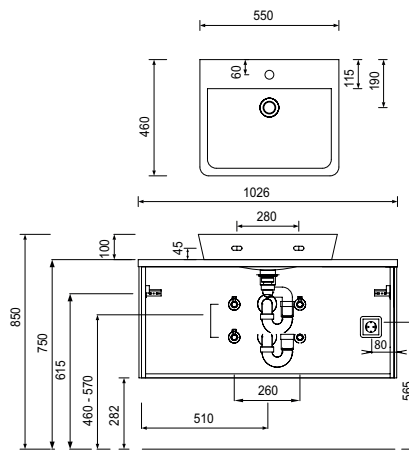
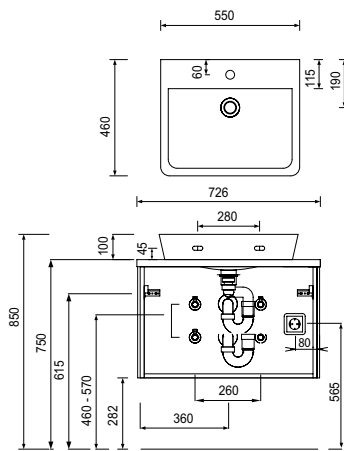

WTA 0805 + SET 3810 R

WTA 0805 + SET 382S

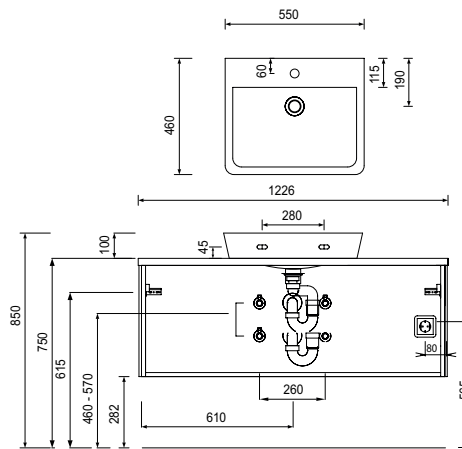
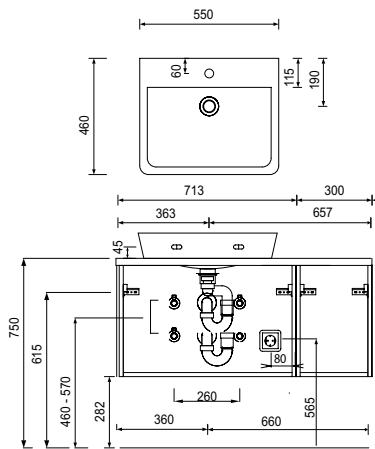

WTA 0805 + SET 3814

WTA 0805 + SET 3817

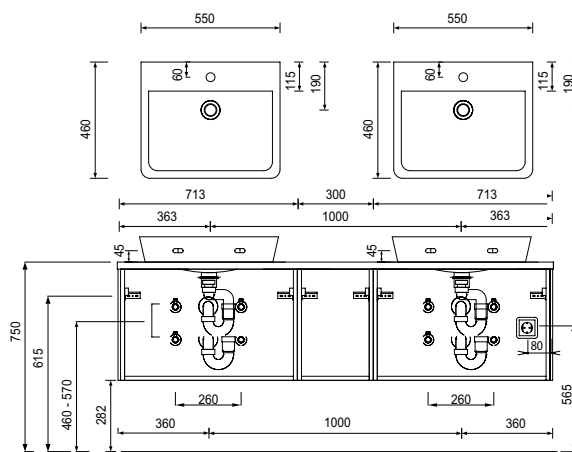
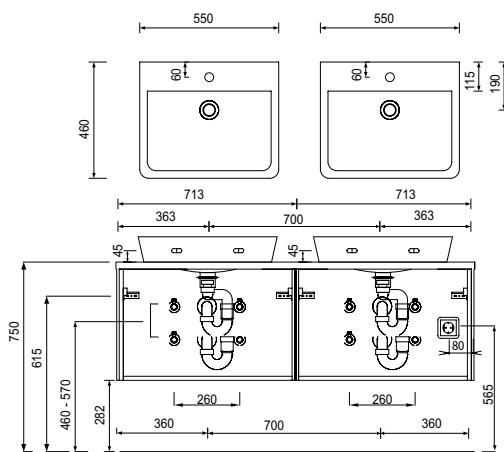

## Toleranzen:

Die Maßtoleranzen (+/- 5mm) und Ebenheitstoleranzen (DIN 18202) unterliegen den üblichen materialspezifischen Toleranzen für Bauwerkstoffe, anlehnd an die DIN 18202.

# Programm 063 - Maßskizzen

WTA 1104 + SET 387S

WTA 1104 + SET 381S

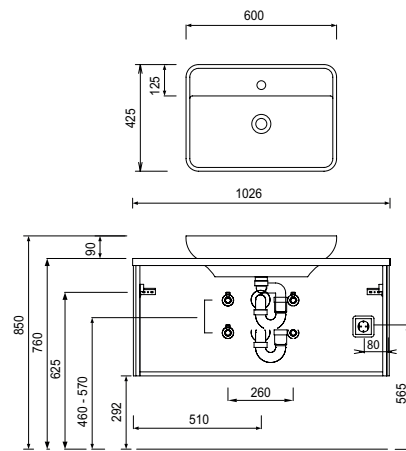
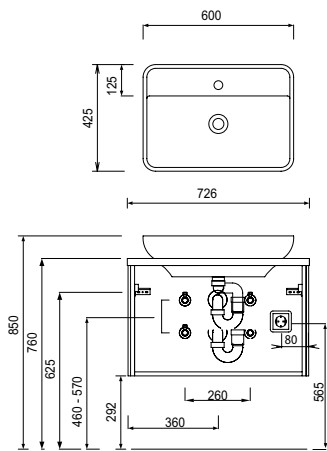

WTA 1104 + SET 3810 R

WTA 1104 + SET 382S

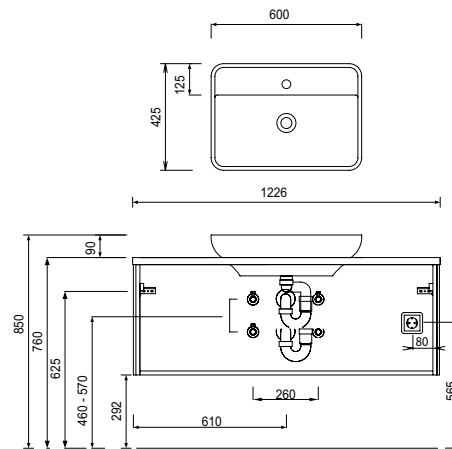
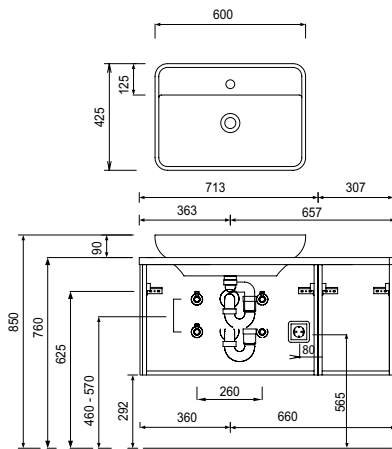

WTA 1104 + SET 3814

WTA 1104 + SET 3817

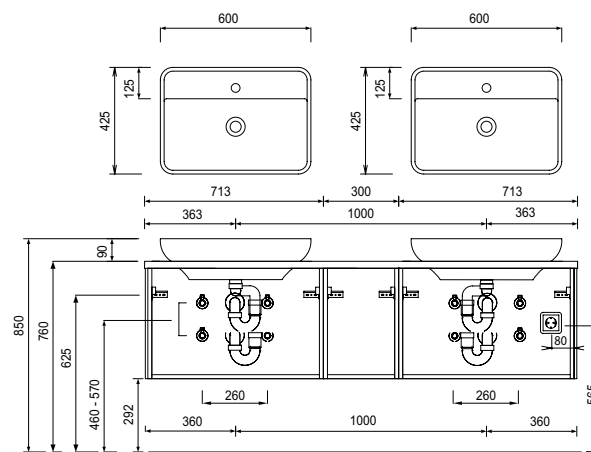
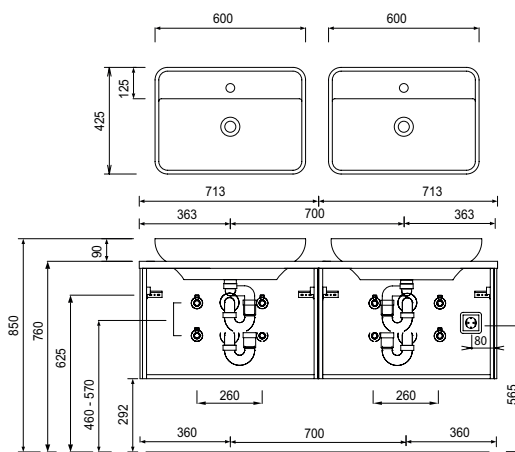

**Toleranzen:**

Die Maßtoleranzen (+/- 5mm) und Ebenheittoleranzen (DIN 18202) unterliegen den üblichen materialspezifischen Toleranzen für Bauelemente, anlehnd an die DIN 18202.