

Programm 066 - Maßskizzen

WTA S111 1 + WUA 3360 P3 +
2x SDH 4978 01

WTA S112 1 + WUA 3390 P3 +
2x SDH 4978 01

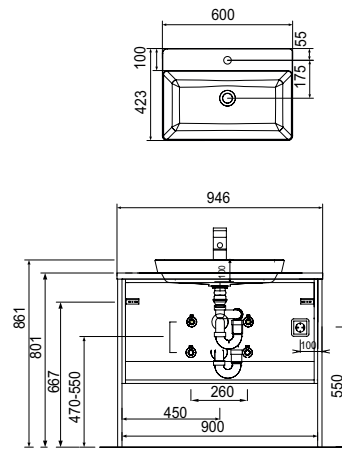
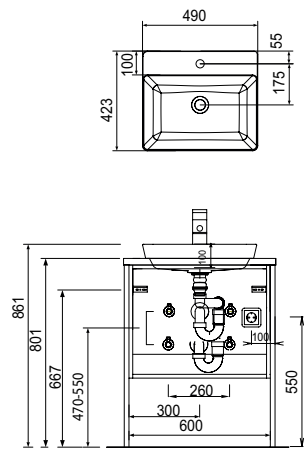

2x WTA S111 1 + 2x WUA 3360 P3 +
2x SDH 4978 01

WTM 4805 + WUA 3360 P3 +
2x SDH 4978 01

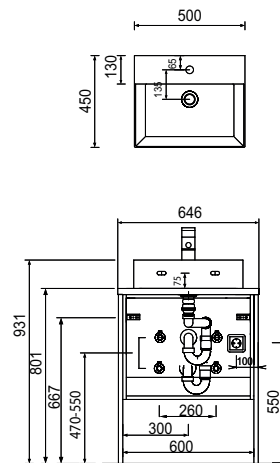
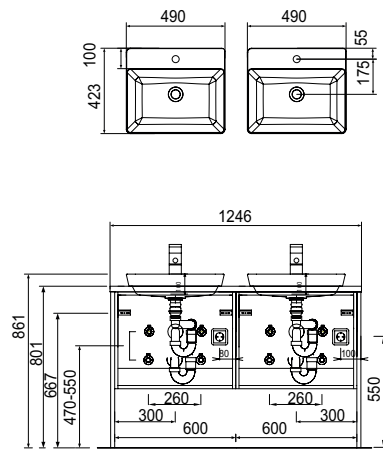

WTM 4806 + WUA 3390 P3 +
2x SDH 4978 01

2x WTM 4805 + 2x WUA 3360 P3 +
2x SDH 4978 01

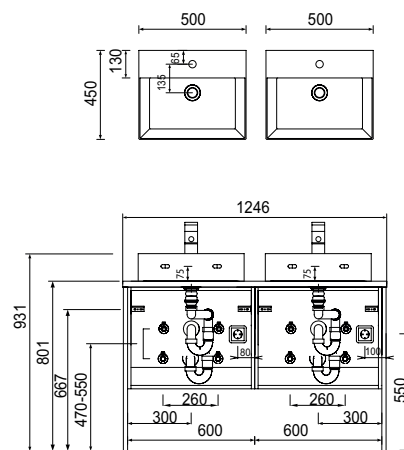
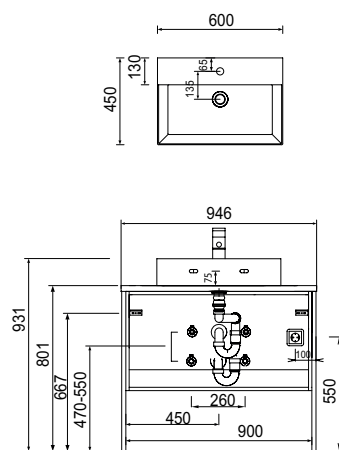

Toleranzen:

Die Maßtoleranzen (+/- 5mm) und Ebenheitstoleranzen (DIN 18202) unterliegen den üblichen materialspezifischen Toleranzen für Baustoffe, anlehnd an die DIN 18202.

Programm 066 - Maßskizzen

WTA S111 1 + WUA 3360 P3

WTA S112 1 + WUA 3390 P3

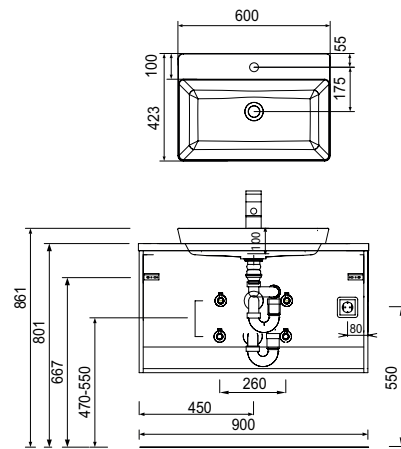
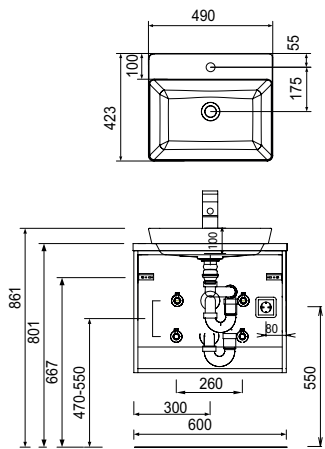

2x WTA S111 1 + 2x WUA 3360 P3

WTM 4805 + WUA 3360 P3

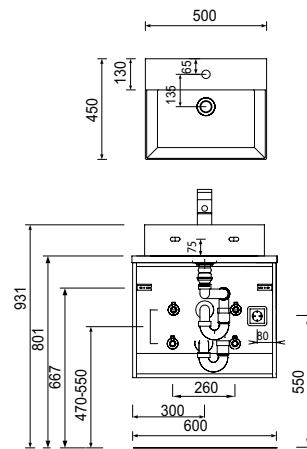
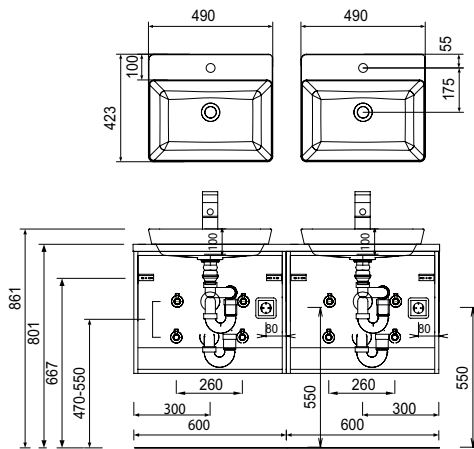

WTM 4806 + WUA 3390 P3

2x WTM 4805 + 2x WUA 3360 P3

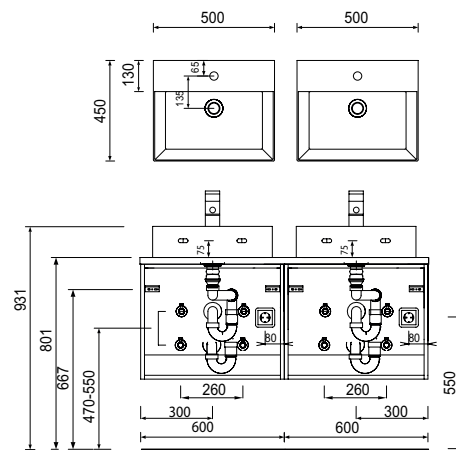
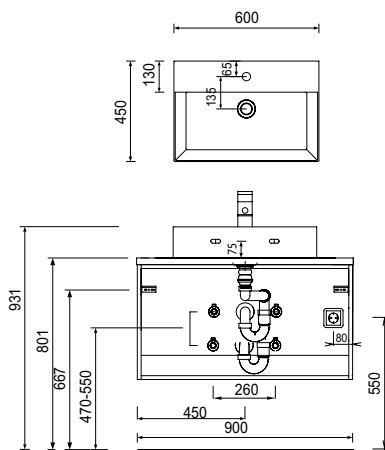

Toleranzen:

Die Maßtoleranzen (+/- 5mm) und Ebenheitstoleranzen (DIN 18202) unterliegen den üblichen materialspezifischen Toleranzen für Bauelemente, anlehnd an die DIN 18202.